



Engine User Manual

Engine No.....

Date: / /



Bellevue Farm, Old North Road
Bassingbourn, Royston
Herts, SG8 5JR, UK
Tel: +44 01763 246660
email: sales@baileyaviation.com
www.baileyaviation.com



Welcome

Congratulations on the purchase of your Bailey V5/V5E engine, please thoroughly read this owners manual before proceeding to mount or start your new engine.

Every care has been taken to make this manual as accurate and instructive as possible and all data and procedures are correct at the time of printing. However Bailey Aviation reserve the right to make specification and detail changes to any part of their equipment, manufacturing processes or this manual without recourse.

For the latest version of this manual, please visit the download section of our website at www.baileyaviation.com.

This manual covers the component parts of the engine, the mounting, running-in, starting/stopping procedures and to offer guidelines on maintenance and proper up-keep of your Bailey V5 engine. Whilst we list pre-start checks, this manual is NOT a substitute for professional flight training.

We strongly advise that you seek fully professional training and obtain any licence or aviation clearance necessary to fly a Bailey V5 in your country.

We wish you many happy hours with your new engine.

Manual Contents

Page No	Description
1	Variants / Description / Applications
2	Specification
3	Components
4	Mounting Schematics / Dimensions
5	Wiring Diagram – V5
6	Wiring Diagram – V5E
7	Installation Notes
8	Adjustments & Set-up
9	Pre-start Checks / Warnings
10	Operation Notes / Running-in / Starting
11	Service Schedule
12	Maintenance Procedures (oil & filter)
13	Maintenance Procedures (drive belt & valve clearances)
14	Parts List
15	Warranty / Disclaimer
16	Notes

Engine Supplied parts

Your Bailey V5 engine is supplied complete with the following components:
Exhaust System, carburettor, air filter, wiring loom, CDI ignition and fuel pump.

In addition to the above, the V5E electric start variant is also supplied with:
Starter motor, starter solenoid and voltage regulator.



Engine Variants

The engine is available as a manual (pull) start, known as the V5 or an electric start, known as V5E. The V5E comes with 80W engine generator and voltage regulator/rectifier.

V5 and V5E engines are both available with the unique Bailey Quick Release Propshaft (BQRP) with single bolt attachment. All references in this manual will be to the V5 and will apply to the manual start variant, any differences with the V5E will be clearly indicated.

Engine Description

The V5 is the fifth generation of the world championship-winning Bailey Aviation 4-stroke engine, offering smooth, progressive power with low noise levels and superior fuel consumption. The culmination of 10 years producing engines, the V5 is our lightest and most compact design, offering effortless pull starting and a wide power band from idle to maximum RPM.

The Bailey V5 engine is a lightweight single cylinder 4-stroke engine with the unique 'Bailey Easy Start System' (BESS). This System enables the high compression V5 to be easily pull started by releasing 80% of the compression during cranking. Once started the system automatically disengages.

The V5 features a 2-piece CNC machined cast alloy crankcase, has a capacity of 195cc with two valves operated by a chain driven overhead camshaft. The oil system is fully pressurised with a pressure relief valve thus maintaining constant oil pressure regardless of the oil temperature or RPM.

The cylinder bore features a special coating for increased wear resistance and the crankshaft design features oversize bearings and an internal needle-roller bearing.

The crankshaft runs on two main bearings with a third bearing to accommodate drive belt loads. The integral prop speed reduction unit (PSRU) is driven via a Poly-V belt with eccentric belt tension adjustment.

Ignition is CDI (capacitive discharge) with integrated variable advance curve.

Carburation is by float type carburettor (CVK26) with a K&N air filter with rubber mounted anti-vibration bracket, fitted to any alloy inlet manifold.

Engine cooling is taken care of by our forced air cooling system, using a crankshaft mounted fan, ducted around the cylinder and head by our all-new injection moulded engine cowling, which also neatly houses the pulse fuel pump. The ignition CDI unit is also directly mounted to the engine on a custom bracket, making for an incredibly neat installation.

The engine has a 3 stage oil filtering system, with a replaceable oil filter that is easy accessible and a glass oil level window so you can easily check the oil level.

The exhaust silencer and downpipe are made from 304 Stainless steel for longevity, with a chrome plated engine-mounted mild steel exhaust bracket which houses our heavy duty sprung exhaust mounting clamps to allow for thermal expansion/contraction of the exhaust under all engine temperatures.

Every V5 engine is fully tested on our in-house test rig prior to being signed off for customer release.

Applications

Intended applications for the Bailey V5 and V5E engines are: -

- Paramotors
- Paratrikes
- Single Seat hangglider trikes
- Motorgliding
- Small single seat de-regulated aircraft (UK SSSR)
- U.A.V's (un-manned aerial vehicles)
- Hovercraft

V5 Engine Specification

Manufacturer	Bailey Aviation, United Kingdom
Type	Single cylinder 4 stroke, forced air cooled, 2 valve per cylinder, cast alloy.
Displacement	195cc
Bore/Stroke	65x59mm
Crankshaft	3 Bearing roller
Piston	Forged alloy, 3 ring
Oil System	Wet sump with pressure pump and 3 way oil filtration and P.R.V.
Fuel system	CVK float bowl carburettor with pulse pump
PRSU/Reduction	3.19:1 reduction with poly-V drive
Prop Mounting	6 x 75mm PCD M8 studs or BQRP single bolt + 'R' Clip
Exhaust	Stainless steel
Starter	Manual pull start with rope rewind (recoil)
Ignition System	Variable advance CDI
Oil Capacity	500cc
Oil Type	Fully Synthetic 10W40 or 10W60 4 stroke motorcycle oil (Putoline Off Road Nanotech 4+ 10w/60 recommended) (Spec – JASO – MA2 –API –SL)
Mountings	4 x M8 bonded rubber 'Silent blocs'
Spark Plug type	NGK CH7SA (or equivalent)
Spark Plug Gap	0.60mm (0.24")
Air filter	K&N R-1070
Oil Filter	Pleated paper (order from Bailey Aviation)
Drive belt tension	5-8mm Deflection at mid span point with 10Kg force
Valve clearances	0.10mm (0.004") for inlet and exhaust valves
Fuel Type	95-99 (Ron) Octane unleaded fuel, AVGAS not recommended
Engine Weight	15.8Kg (manual start)

V5E Engine Specification (in addition to above)

Starter Motor Type	Pre-engaged
Battery Recommendation	12v 5ah minimum – Lead Acid or Lead Gel type only (see note below)
Engine Generator	80W
Engine Weight	17.0Kg



The V5E voltage regulator is not compatible with LiFePO₄, LiPo or NiMH batteries. Battery must be Lead Acid or Lead Gel type.

V5 / V5E Engine Performance & Limitations

Power Output	20.5hp @ 8200 RPM
Thrust Output (static)	>60Kg when used with recommended Helix 1.30m propeller
Max Power RPM	Limited to 5 minutes
Max Continuous RPM	7500 RPM
Oil Temp	Max 180°C Min 50°C
Cyl Head Temp	Max 220°C Min 50°C

V5 Engine Component Parts

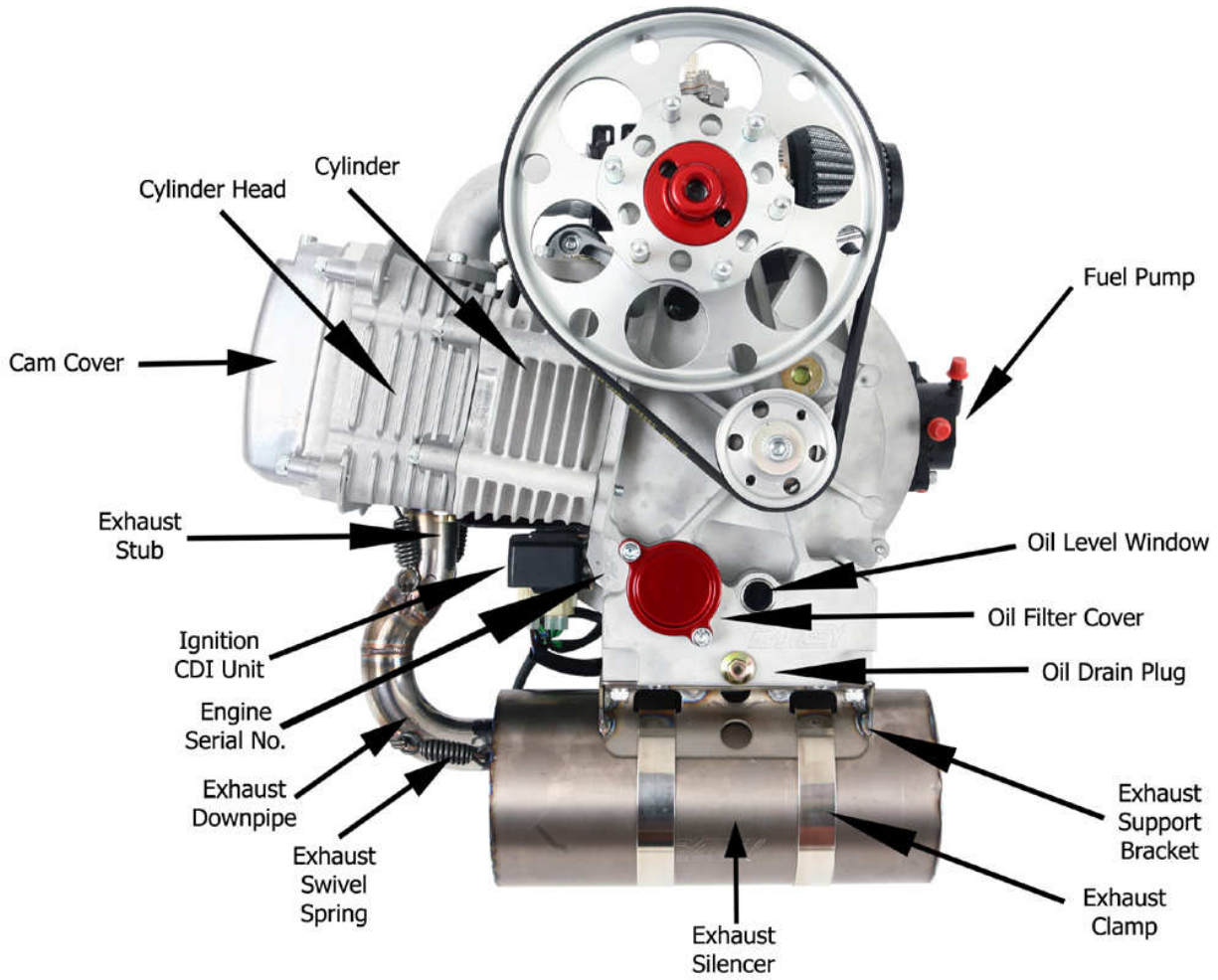

V5E Electric Start

The pictures below show the starter motor location and design and also the V5E wiring loom, which includes the voltage regulator.

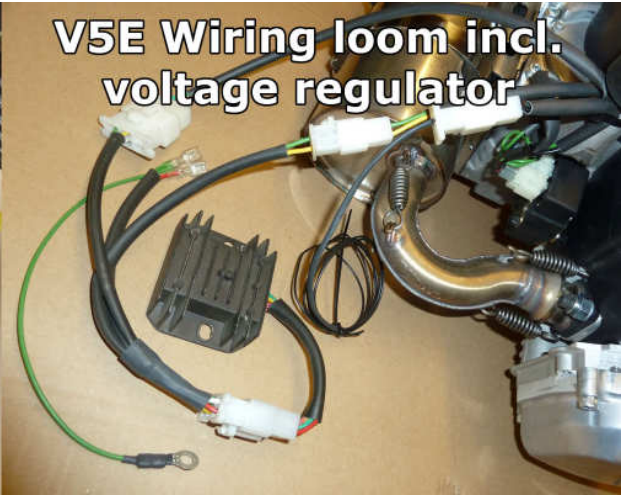
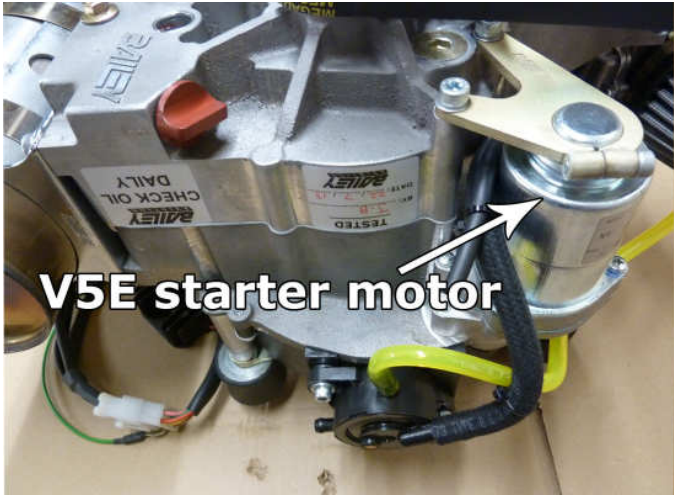

Engine Mounting Schematic / Dimensions

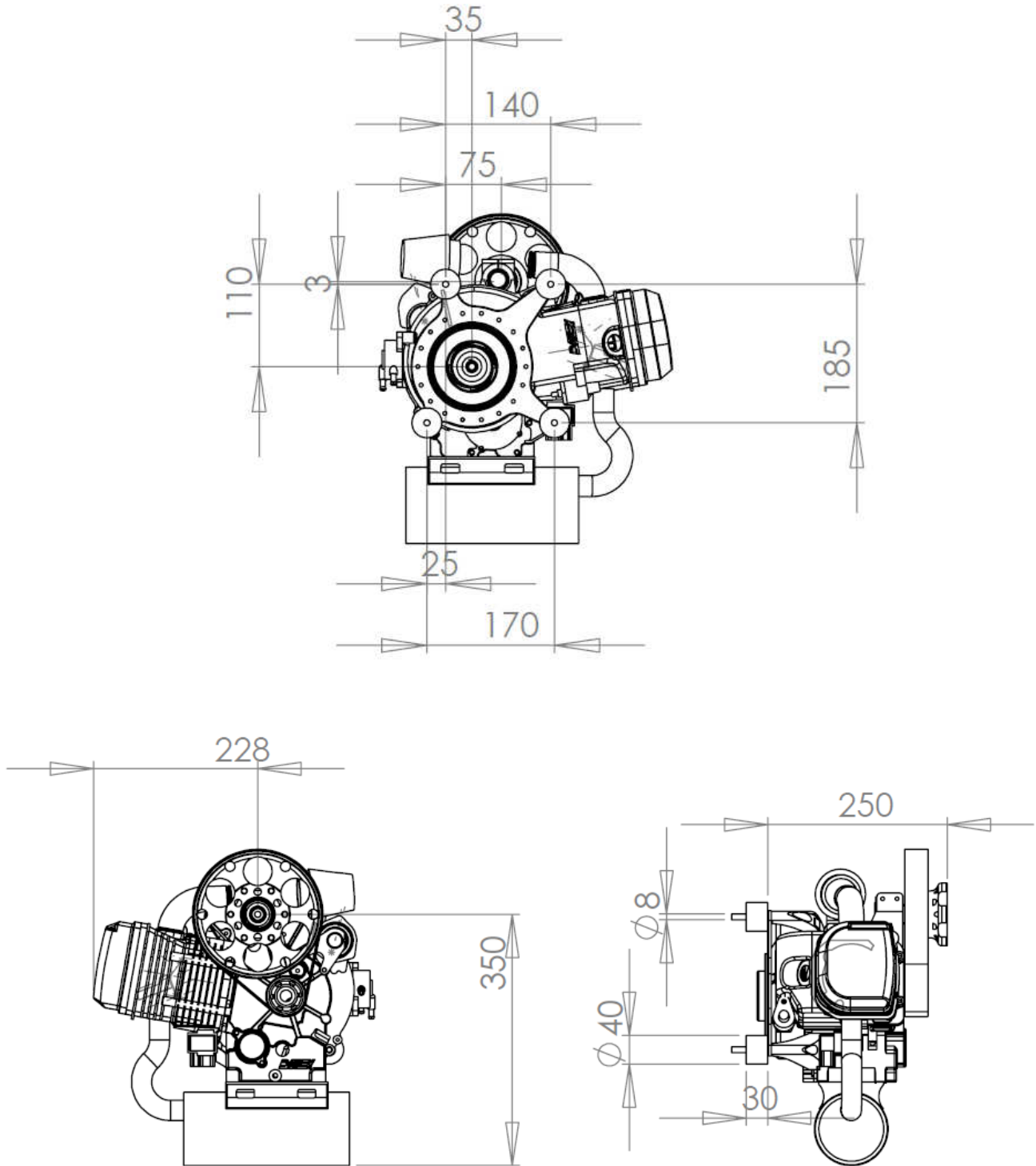

Wiring Diagram – V5 Engine

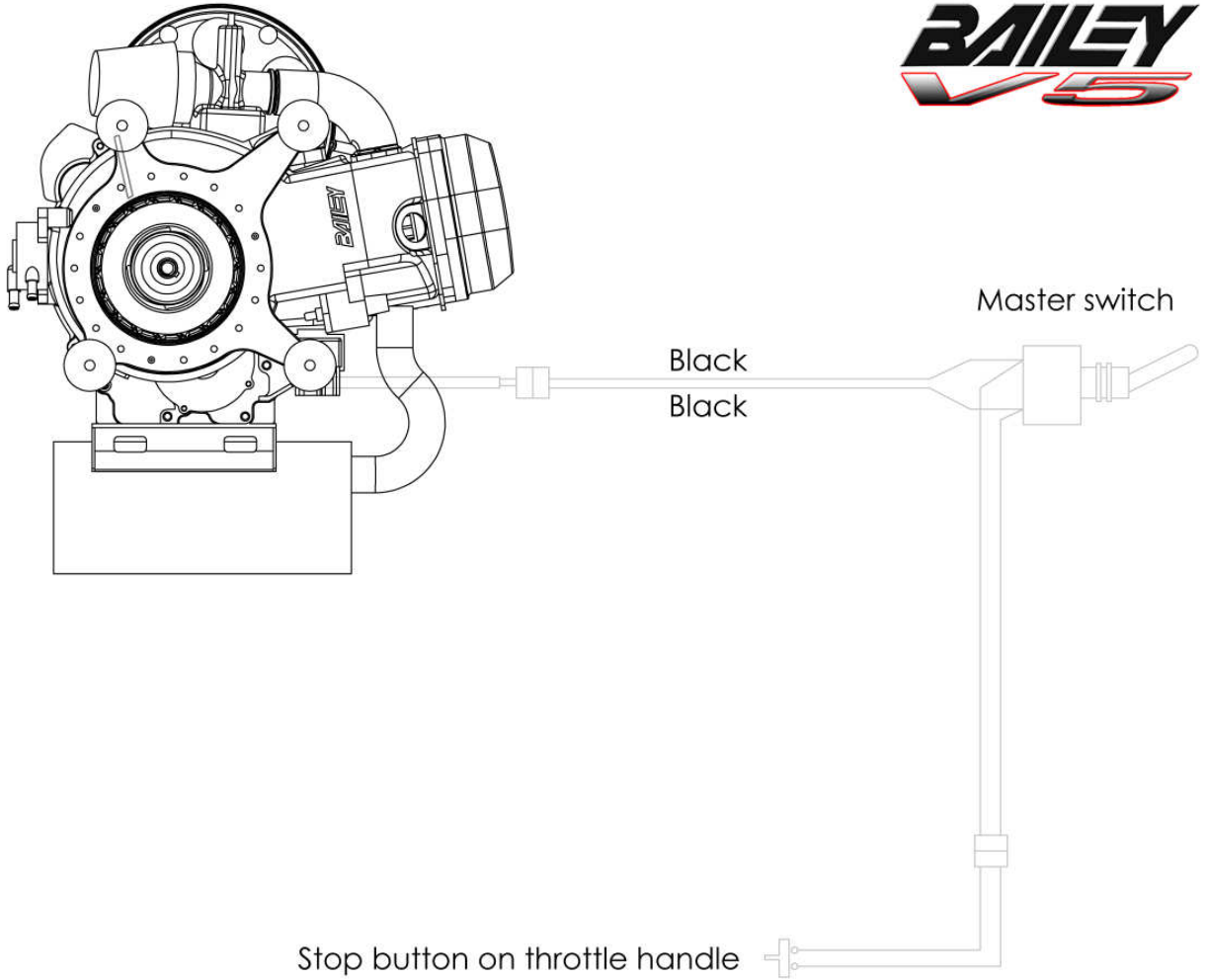

Wiring Diagram – V5E Engine

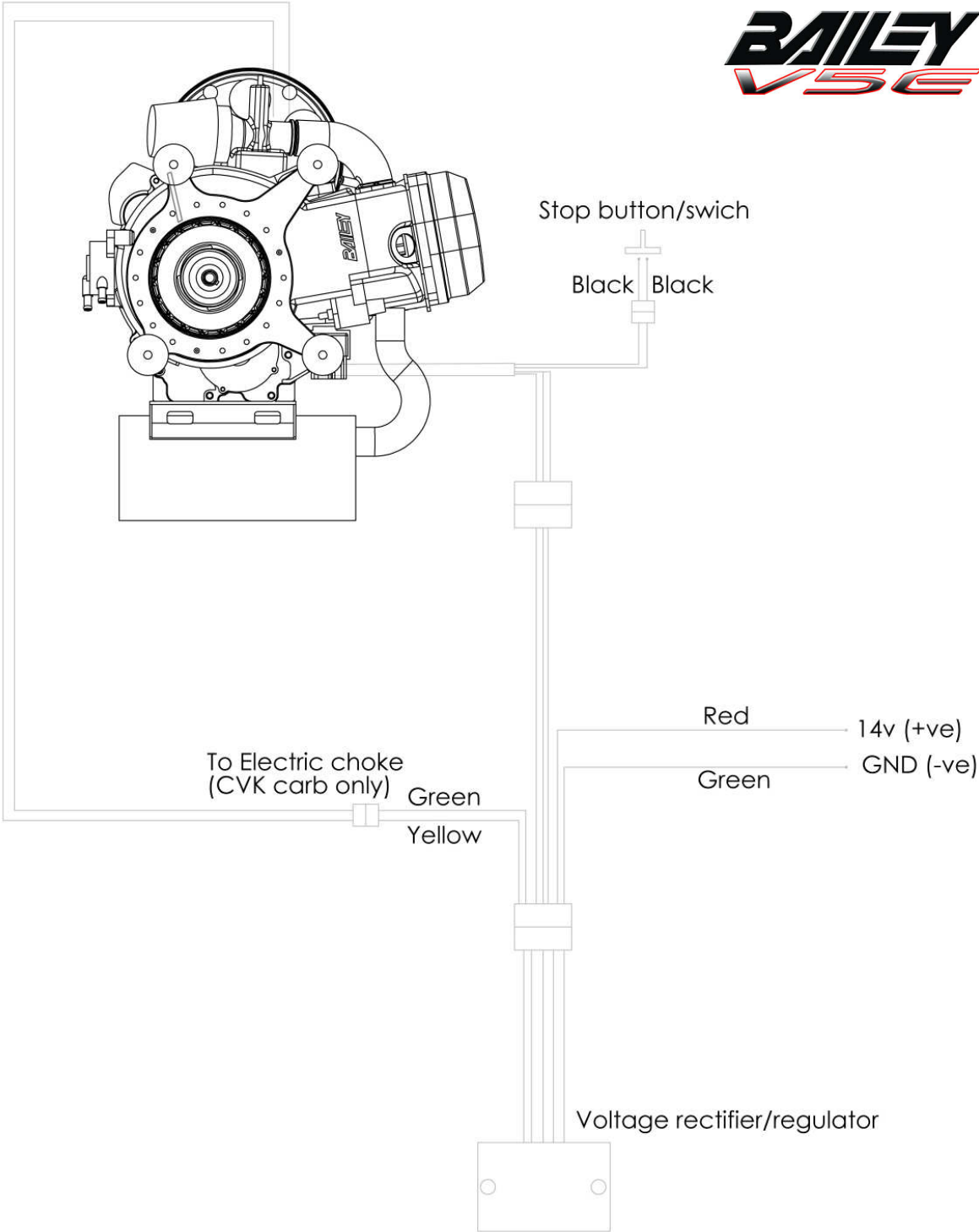

Installation Notes

We recommend a 2 position N.O. (normally open) master switch as well as a momentary push button (N.O.) switch to stop the engine. The Bailey Easy Start System (BESS) makes the engine very easy to start - Remember always safety first !

The V5 engine is provided with a 2-pin plug with a pair of black cables. Connecting these two black wires together stops the engine. The V5E comes with an additional wiring loom and voltage regulator.

Warning: The engine must be left at idle speed for at least 10 seconds prior to stopping, this allows the internal exhaust components to sufficiently cool to prevent ignition of fuel in exhaust during rundown. Failure to do this can result in exhaust damage.

The V5 carburettor is filled with a vent tube fixed to the top slide screw and a return pipe, which must be returned to the fuel tank. The routing of this return pipe must be arranged so that there is a constant 'fall' to the fuel tank with no possibility of fuel 'puddling' in the line. Modification of the fuel breather and return lines in any way will cause carburetion problems.

Engine Breather Pipe

The engine must be fitted with a breather pipe connected to the cam cover outlet, minimum 6mm I.D. hose and minimum hose length of 500mm. Without this specification pipe fitted the engine may eject oil from the breather.

Fuel Line attachment

The fuel feed line must be attached to the fuel pump inlet and a suitable filter installed upstream of the pump. We recommend a 'primer' bulb of some sort upstream of the pump to enable manual filling of the carburettor prior to starting.

Choke

The V5 CVK carburettor has no choke (cold start enrichment device) fitted. Instead there is an accelerator pump connected to the throttle mechanism.

Propeller

Recommended 'pusher' propeller is Helix 1.30m, part number H30F 1.30m L-NM-7-2 (6xM8x75 / 25.4)

If attached using standard 6-stud configuration, nut torque is 10-15lbs/ft (15-20nm). Tighten opposite nuts gradually until the desired torque is reached. With this attachment system a prop-tracking test must be performed after every fitment. Maximum blade difference is 3mm.

If attached using BQRP (single bolt) tighten central socket cap bolt to 10-15 lbs/ft (14-21nm), allowing the hole drilled through its head to line up with the hole in the cover plate. If the hole in the head of the bolt and cover plate do not line up when torqued between 10-15lbs/ft (14-21nm), then slacken the bolt, turn the cover plate 1/6 of a turn clockwise or anti-clockwise and re-tighten the bolt. Once the hole in the bolt head and cover plate are aligned, push the metal R clip through the assembly

Throttle cable

The V5 is not supplied with a throttle cable, but this can be ordered as an optional extra. Ensure the throttle slide closes fully with every possible orientation when using a flexible 'hand' throttle assembly.

The stop button should ideally be placed in a position where it is very easy to press. We accept that the occasional inadvertent pressing of the stop button during launch is much preferable than failure to reach it in an emergency/aborted take-off.

Propeller clearance

Radial and lateral propeller tip clearance should be at least 50mm.

Exhaust clearance

Minimum distance from any point of the exhaust system to any fuel tube or tank should be 60mm in an 'open' installation and 100mm in a 'cowled' installation.

Forced Air cooling Intake

There must be sufficient clearance for cooling air to enter the engine cooling fan housing.

The cross sectional area of the intake (9503mm²) must be maintained or enlarged in every part of a cowled installation. In the case of a flat plate covering the air intake, the intake cross sectional area must be maintained; therefore the recommended minimum clearance is 28mm (9676mm²)

Please note this is a minimum and does not allow for thrust compression of the engine mounts.

Adjustments - Carburettor Idle Speed

The Idle speed is adjusted by turning the small screw on the side of the throttle quadrant as shown in the picture.

The idle speed is factory preset, but should be 2600-2900 RPM



Adjustments - Exhaust Spring Tension



The V5 exhaust uses two T-bolt clamps around the silencer that allow for expansion/contraction of the exhaust assembly. These clamps are factory pre-set to provide optimum clamping force. Should you need to adjust the clamps, you need to leave a 0.5mm gap between each coil of the spring as shown in the picture.

Pre-Start Checks - Warnings

Before proceeding to check over your engine, make sure that the master switch is in the 'OFF' position. The Bailey Easy Start System (BESS) makes the engine very easy to start - Remember always safety first !

Engine Oil Level - With engine placed on a flat surface the oil level should be between the half way (min) and top (max) of the glass oil window.

Fuel System - Ensure you have sufficient fuel for the planned flight.

Exhaust System - Ensure exhaust system is secure, check swivel springs at both ends of the downpipe and also the condition of the T-bolt clamps. DO NOT tighten T-bolt clamp nyloc nuts, these are factory pre-set to provide optimum clamping force, whilst allowing for sufficient expansion/contraction of exhaust assembly (There must be 0.5mm gap between each coil of the springs – see page 8).

Air Filter / Carburettor - Ensure that air filter is in good condition, tightened securely and is not soiled or blocked. Check securing bracket is in good condition and fastened correctly. Check the condition of the rubber connector between carburettor and inlet manifold and that the two constant tension spring clips are located correctly.

Spark Plug HT Lead – Check that the HT lead cap is fully pushed onto the plug. It is not necessary to remove/check spark plug before each flight (this is not a 2 stroke engine!). Repeated un-necessary removal of the spark plug cap will cause it to become loose.

Cooling Air Inlet - Ensure there is no restriction to air entering the cooling fan inlet.

Throttle Assembly - Visually check for full throttle travel on the carburettor and ensure throttle closes fully and smoothly.

Reduction Drive / Propeller - Check that propeller is free from cracks and chips. Check the six securing studs/nuts are tightened to the specific torque setting (7lbs/ft [10nm]). If BQRP single bolt system is fitted, check bolt is tightened to specific torque setting (10-15lbs/ft [14-21nm]) and that safety 'R' clip is fitted. Turn propeller by hand (make sure master switch is off) in either direction through a full 360° rotation and check for sufficient clearance of all components. Minimum clearance from propeller tip to any other part of your aircraft should be 50mm.

Drive Belt – Check the Poly-V drive belt for cracks or wear.

Ground Running - Bailey Aviation recommend that you **DO NOT** 'Ground run' the engine. Experience has proven that the **ONLY** safe place to run a paramotor engine is with it firmly strapped on your back. All pre-flight power checks are best performed whilst wearing the paramotor on your back. This is much safer and prevents stones or debris being drawn into the propeller.



Propellers can be very dangerous, **DO NOT** start engine where there is any chance of the propeller coming into contact with the operator or any other person or object.

Operation Notes

Prior to starting your Bailey V5 engine, you should have already followed the full pre-start checklist shown on page 9.

Ensure propeller cannot contact anything or anyone. (In the case of a paramotor, machine must either be 1. Securely strapped to a pilot or 2. Securely fixed to proprietary test rig.)

DO NOT start your paramotor unless one of these 2 rules is obeyed.

Running-in

Your V5 engine has been fully tested prior to customer release, but you must adhere to the following procedure to ensure no damage is caused to your engine in the first few critical running hours. After the first 10 running hours, your engine will be run-in and you must perform an oil and filter change and check the valve clearance settings, as is shown on the service schedule on page 11.

During the running-in period (first 10 hours) full power can be used for take-off. Once airborne power should be reduced to a maximum of 75%. Varying the engine RPM during this period is recommended. Running-in on the ground is strongly discouraged.

Starting

On the V5 (manual start) CVK carburettor there is no choke (cold start enrichment device) fitted. Instead there is an accelerator pump connected to the throttle mechanism. On V5E (electric start) models there is an electric choke unit fitted.

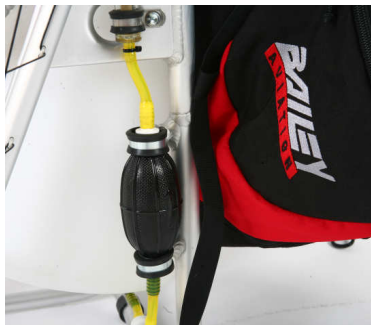

Example of suitable primer bulb on a Bailey Aviation paramotor



Example of pull start handle mounting on a Bailey Aviation paramotor

Starting – Cold Start:

- A) First ensure the carburettor is full of fuel by squeezing the primer bulb
- B) Check throttle is closed fully, after opening and closing to test operation
- C) Pump the throttle several times (5-10 times, depending on temperature)
- D) Keep the throttle very slightly open
- E) Use pull starter handle to start engine
- F) Once started maintain a fast idle for at least 60 seconds
- G) Momentarily press stop button to check operation

If the ambient temperature is very cold you will need to continue pumping the throttle after starting to maintain a rich mixture for the first 10 seconds or so, until the engine has reached a sufficient temperature.

Starting – Hot Start:

- A) Keep the throttle very slightly open
- B) Use pull starter handle to start engine



Service Schedule

Please adhere to the following service schedule to keep your Bailey V5 engine in perfect condition – Failure to carry out the necessary action at the selected frequency may cause poor running or more serious problems that may affect your warranty

FREQUENCY	ACTION
Before and after each use	Check Oil Level
	Visually check fuel connections
	Check exhaust security
	Check that throttle returns to fully closed position and full throttle can be obtained
	Check propeller leading edge for damage
	Check <i>all</i> securing nuts/bolt/engine mounts
After Initial 10 hours (first service free for UK residents)	Replace engine oil & filter
	Check valve clearances
Every 25 hours	Replace engine oil & filter
	Check drive belt tension
	Check valve clearances
Every 100 hours	Check and reset spark plug gap
Every 200 hours	Renew spark plug
	Replace engine mounts
	Replace drive belt
	Remove & wash air filter (with genuine K&N filter cleaner only – do not oil!)
Every 500 hours (T.B.O.)	Contact Bailey Aviation regarding 'Zero Hour' overhaul or time extension

Storage Instructions ('Laying Up')

If you are not using your machine for a long period of time (3+ months) then we recommend following the notes below to keep your machine in good condition.

- 1) Loosen drive belt
- 2) Remove and drain fuel tank
- 3) Drain carburettor float bowl, with drain screw open, squeeze primer bulb and evacuate all fuel from system and then re-tighten screw

Returning the machine to service after 'Laying Up' :

- 1) Drain and renew engine oil
- 2) Refuel
- 3) Re-tension drive belt
- 4) Thoroughly follow pre-flight checks prior to starting machine

Maintenance Procedures – Oil & Filter Change

Please note that the engine must be up to normal operating temperature before draining oil.

- 1) On a flat/even surface, place a small block of wood under the front of the chassis, effectively tilting the engine backwards (to stop drained oil from dripping onto the exhaust system)
- 2) Remove the oil drain plug with a 10mm socket
- 3) Drain all used oil into a suitable container
- 4) Remove wooden block so that engine is now level
- 5) Replace and tighten oil drain plug with a 10mm socket (do not overtighten)
- 6) The oil filter cover is located on the pulley side of the engine, to the left of the oil level window. Loosen & remove the two socket cap screws with a 5mm allen key, turn the cover to enable it to be easily removed and place the cover on a clean surface.
- 7) Next remove the old paper oil filter element and replace with a new filter (available from Bailey Aviation) and replace cover and socket cap screws.
- 8) Remove red anodised oil filler cap (**DO NOT** turn propeller with the filler cap removed).
- 9) Carefully fill with fully synthetic 4 stroke motorcycle oil (see Page 2 for recommended oil types) until the oil is at the top of the oil level window.
- 10) Replace and tighten red anodised oil filler cap
- 11) Run Engine then recheck oil level and top up oil as necessary

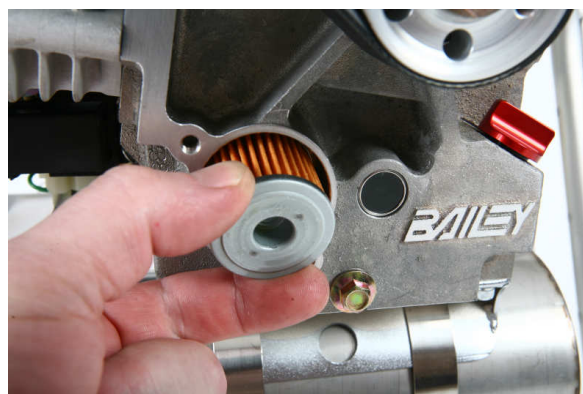
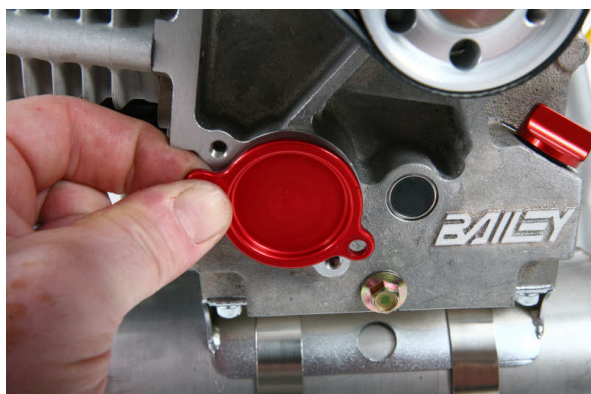

Ensure oil filter is fitted correctly with the black rubber seal **TOWARDS** the engine. Incorrect fitment of the filter will result in engine damage.

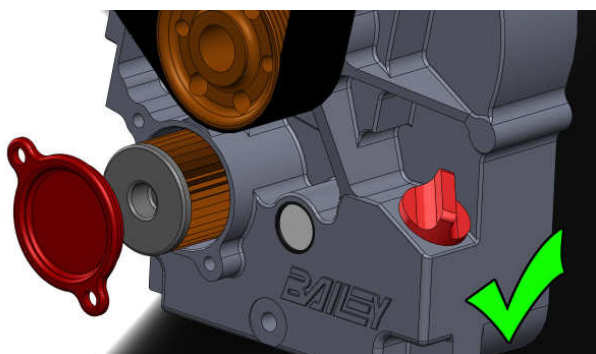

CORRECT

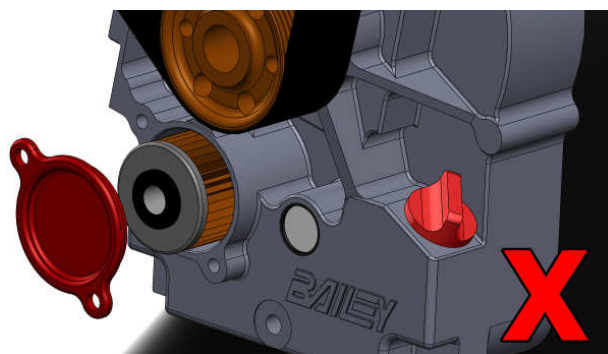

WRONG

Maintenance Procedures – Drive Belt Tensioning

The ideal drive belt tension is the minimum required to prevent any slippage. Some slipping (slight chirping noise) at idle is quite normal. We recommend an optimum belt deflection of 5-8mm (as shown in picture below)

There is a simple test to tell if the drive belt is slipping; From cold allow the engine to briefly warm up and then hold at full power for 10 seconds and stop the engine. If the drive belt is cold to touch, then the tension is correct, if it feels hot then it may be slipping and will require adjusting. The belt will be pre-tensioned at the factory and is checked at the free 10hr service we offer.

We have often found that even after 200 hours, no drive belt adjustment has been necessary.

The drive belt can be adjusted by slackening the two M6 bolts on the top of the reduction pylon, wedging the pylon apart slightly at the split using a small screwdriver and turning the eccentric drive belt adjuster, with an 8mm Hex key inserted into the centre of the large reduction pulley, a slight clockwise rotation will tighten the belt, anti-clockwise rotation will loosen the belt. After adjustment re-tighten the two M6 bolts and test the belt deflection.

N.B. Do not over-tighten belt – This may lead to premature bearing failure and reduction in available thrust.

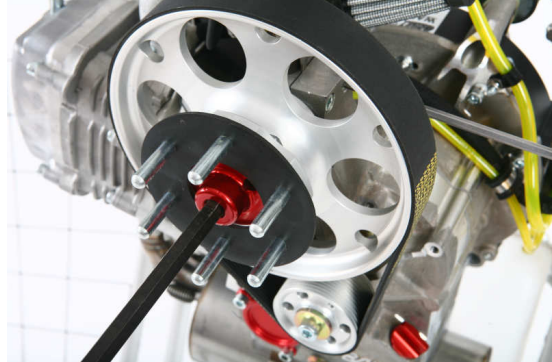
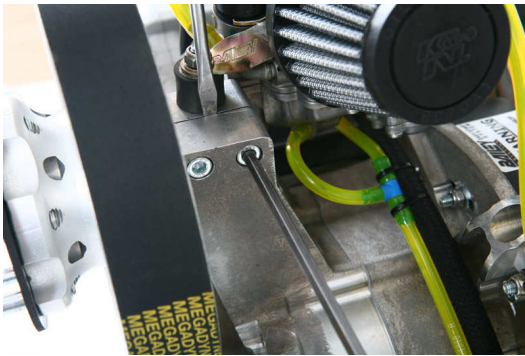
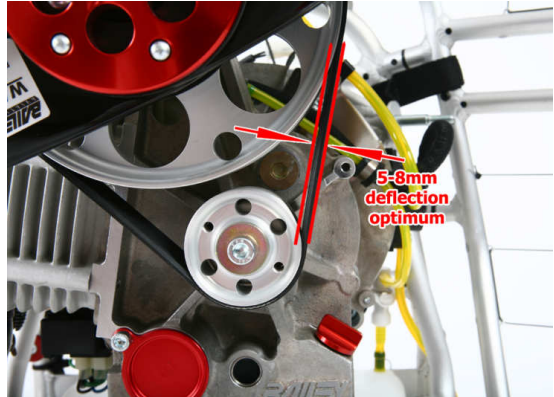

Maintenance Procedures - Valve Clearance Adjustment

Firstly ensure the master switch is off.

Disconnect engine breather hose and remove cam cover. Rotate propeller until inlet valve (nearest the top of the engine) is fully closed and the cam lobe is 180° from the cam follower. Using a suitable feeler gauge, inserted between the valve top and the cam follower adjusting screw, check and/or adjust by loosening the 9mm lock nut (see specifications on page 2 for valve clearances)

The same procedure is used on the exhaust valve (nearest the exhaust), however, be aware of the easy start actuator positioned on the exhaust cam base circle. Make sure the cam follower is clear of this in order to get a correct measurement.



After adjustment ensure both lock nuts are tightened and re-fit cam cover and engine breather hose. Wipe off any excess oil from the lower cylinder head fins.

Parts List

Please find below a list of the parts for your Bailey V5 which we consider to be service or replacement items that may need replacing at certain intervals, due to general wear and tear or as part of our service schedule.

We have also included parts that may be lost in general use whilst carrying out routine procedures prior to flight, we know that small components and a grassy field are sometimes difficult to contend with !

Part No.	Description
V5-OILF	V5 Oil Filter
PUT-NANO	V5 Oil (Putoline Off Road 4+ Nanotech 10W60)
V5-DRIVE	V5 drive belt
V5-QRBOLT	V5 BQRP propeller centre socket cap bolt
V5-QRCLIP	V5 BQRP 'R' Clip
V5-PULPINCLIP	V5 Pull start pulley pin & 'R' Clip
V5-INLRUB	V5 Inlet manifold to carburettor rubber
V5-PROP1.3	V5 Propeller 1.30m Helix Carbon Composite

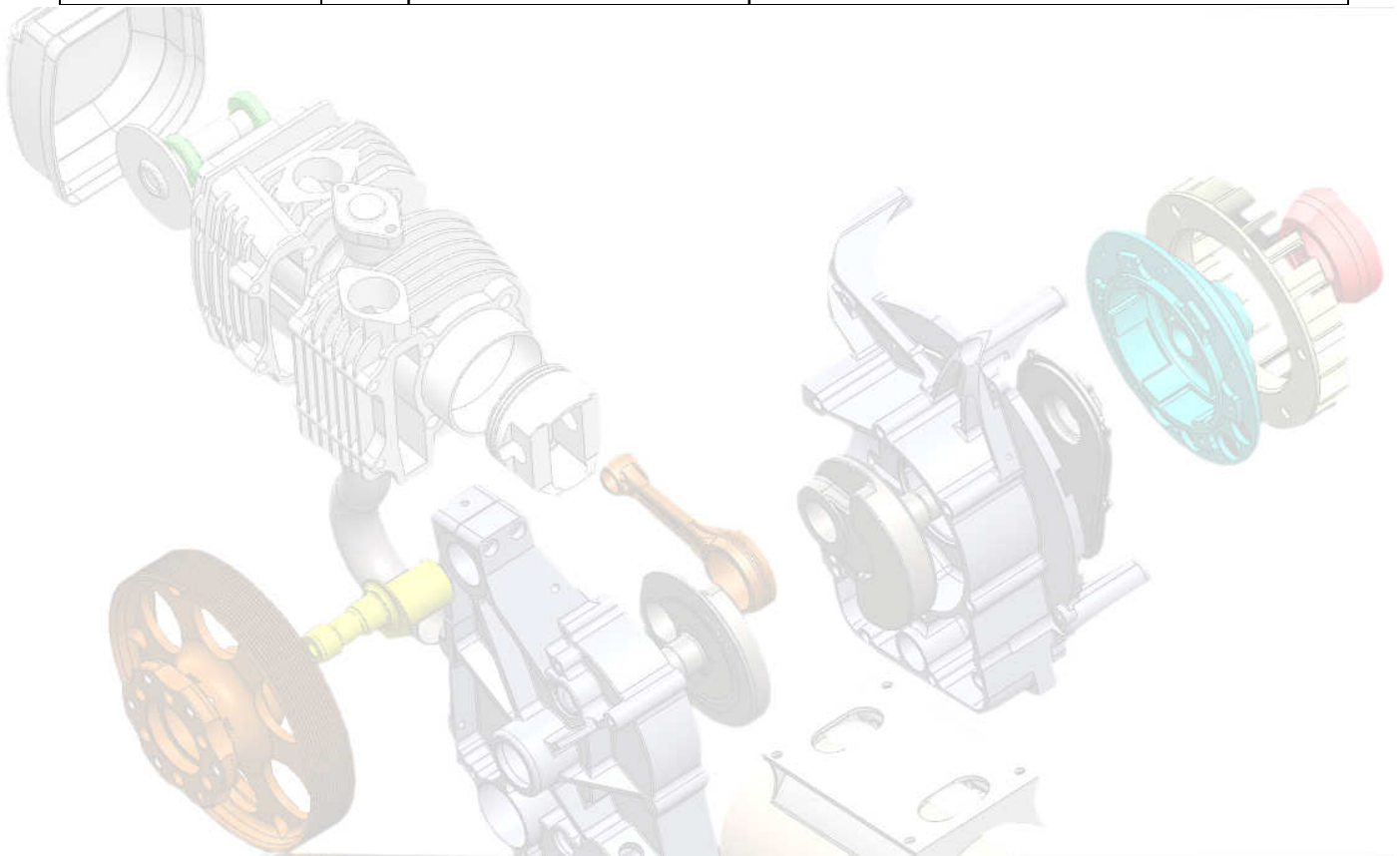



Warranty

Bailey Aviation offers a 12-month limited parts and labour warranty on all engine components for the original purchaser. All warranty claims are return-to-base and can only be carried out by Bailey Aviation. Bailey Aviation cannot be held responsible for the payment of any delivery/freight charges, including customs duties or taxes.

Warranty claims *will not* be accepted for the following situations:-

Damage caused through immersion in water
Damage caused through improper use
Damage caused through failure to carry out proper **PRE-FLIGHT CHECKS**
Damage caused through neglecting the **SERVICE SCHEDULE**
Damage caused by physical dropping, falling or shocks to the paramotor or engine
Damage caused through starting engine without a propeller properly fitted
Damage caused through starting engine with incorrect propeller type
Damage caused through incorrect adjustment of drive belt tension
Damage caused through incorrect adjustment of valve clearances
Damage caused through the use of incorrect fuel or oil type or grade
Damage caused through lack of oil

N.B.

Any modification whatsoever to the engine design, without prior written approval from Bailey Aviation will render the manufacturers warranty null and void.

Disclaimer

DANGER

This engine, by its design is subject to sudden stoppage! Engine stoppage can result in forced landings. Such forced landings can lead to serious bodily injuries or death.

Never fly an aircraft equipped with this engine at locations, airspeeds, altitudes or other circumstances from which a successful no-power landing cannot be made, after sudden engine stoppage. Aircraft equipped with this engine should only fly in DAYLIGHT VFR conditions.

Paramotors and trikes are not certified or licensed aircraft and it is the responsibility of the owner/pilot to use their machine in accordance with the rules and regulations set out by the governing body in their designated country or territory. Bailey Aviation will not accept any claim for damage or death caused through the misuse of any product manufactured or used by them on their products.

WARNING

This is not a certified aircraft engine. It has not received any safety or durability testing and conforms to no aircraft standards. It is for use in experimental, uncertified aircraft and vehicles only in which an engine failure will not compromise safety. User assumes all risk of use and acknowledges by his use that he knows the engine is subject to sudden stoppage.

This manual is for operational guidance on the Bailey V5 & V5E engines only. Use of this engine is entirely at your own risk – Never fly if you are aware of any issues with your equipment, yourself or conditions.

No part of this manual may be reproduced or distributed in any form or by any means without the prior written approval of Bailey Aviation

© Bailey Aviation 2013

E. & O.E.

